

SECTION A-A

ITEM NO.	QTY.	PART NUMBER	DESCRIPTION
1	1	CC0012	CHOKE NIPPLE, 2"1502 STD 15M
2	1	CC0013	CHOKE INDICATOR, 3/4" (FOR 2"CHOKE)
3	1	CC0014	HANDWHEEL, 2" ADJ CHOKE "MSI"
4	1	CC0016	BONNET, 2" H2S 15M MSI MANUAL
5	1	CC0022	CHOKE STEM, 3/4"-1" MAX 15M LONG
6	1	CC0028	CHOKE PACKING, 2", CHEVRON TYPE
7	1	CC0029	CHOKE STEM GUIDE, 2" CHOKE
8	1	CC0030	CHOKE PACKING RETAINER, 2" CHOKE
9	1	CC0037	CHOKE SEAT, 3/4" FC-140 6"LINED CARBIDE
10	1	CC0043	CHOKE BODY, 2"1502 STD 15M
11	1	CC0044	SNAP RING, 2" CHOKE BONNET
12	1	CC0278	BONNET EXTENSION, 2" MSI MANUAL
13	1	CC0281	BONNET THREAD BUSHING, 2" CHOKE
14	1	HC0012	HEX NUT, 5/8"-11 HEAVY HEX 2H
15	1	HC0013	THUMB SCREW, 3/8"-16 x 1.50" (NYLON TIPPED)
16	1	HC0014	FLAT WASHER, 5/8" STD
17	2	HC0111	LOCK WASHER, 1/4" HIGH COLLAR
18	2	HC0176	SOC HD, 1/4"-20 x 2.25"
19	1	HC0177	BALL, 5/16" BRASS CDA270 GRADE 200
20	1	HC0199	GREASE FITTING, 1/4"NPT ALEMITE
21	3	UC0002	WINGNUT, 2"1502 STD
22	2	UC0003	NUT RETAINER SET, 2"1502
23	2	UC0004	SPIRAL RETAINER RING, 2"1502
24	3	UC0011	RESILIENT SEAL, 2"1502 STD (BUNA)

B1

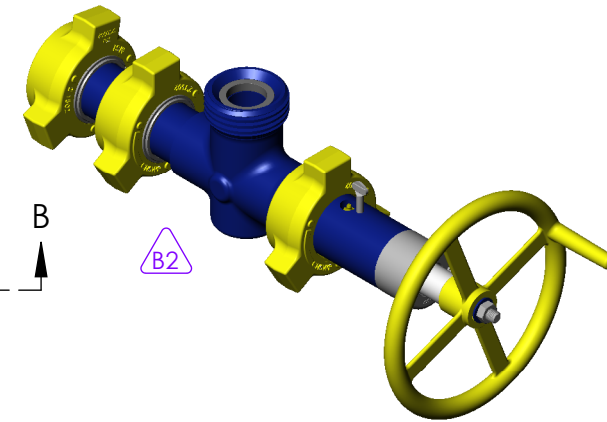
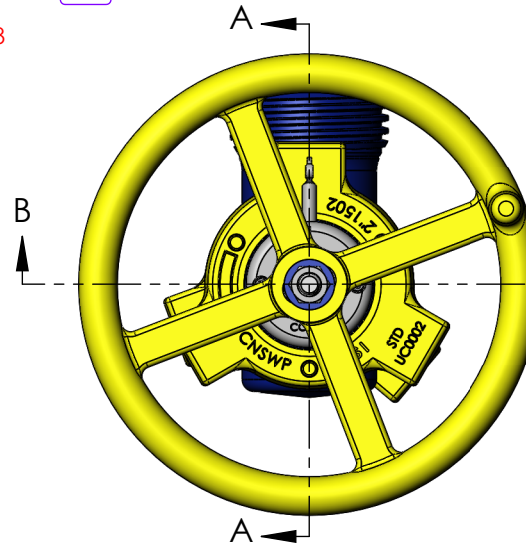

B3

ECN NUMBER 5372 DESCRIPTION ADJ CHOKE, 2"1502FM STD 15M 3/4"MAX

CHANGE MADE	REVISED BY	LMS	DATE	2/4/2015
1)	REPLACED UC0012 WITH UC0011			
2)	ADDED ISOMETRIC VIEW			
3)	UPDATED DRAWING TEMPLATE			
4)	ADDED SHEET			
5)	ADDED DETAIL OF PACKING ORIENTAION			
6)	DIM WAS DECIMAL: NOW FRACTIONAL			
7)				
8)				

WORKING PRESSURE:	TEMPERATURE CLASS:	DRAWN BY:
15,000 PSI	PU	HAHII
RETAINED FLUIDS:	PR LEVEL:	DATE:
BB	1	3/19/02
WEIGHT:	SHEET:	PART NUMBER:
106 LBS.	SHEET 1 OF 2	CA0021



1 2 3 4 5 6 7 8

A
B
C
D
E

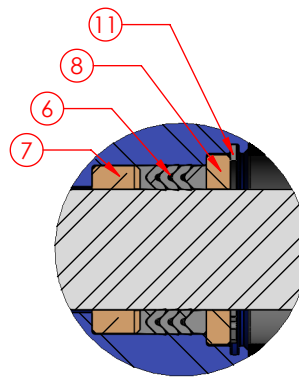

DETAIL C B5
PACKING ORIENTATION

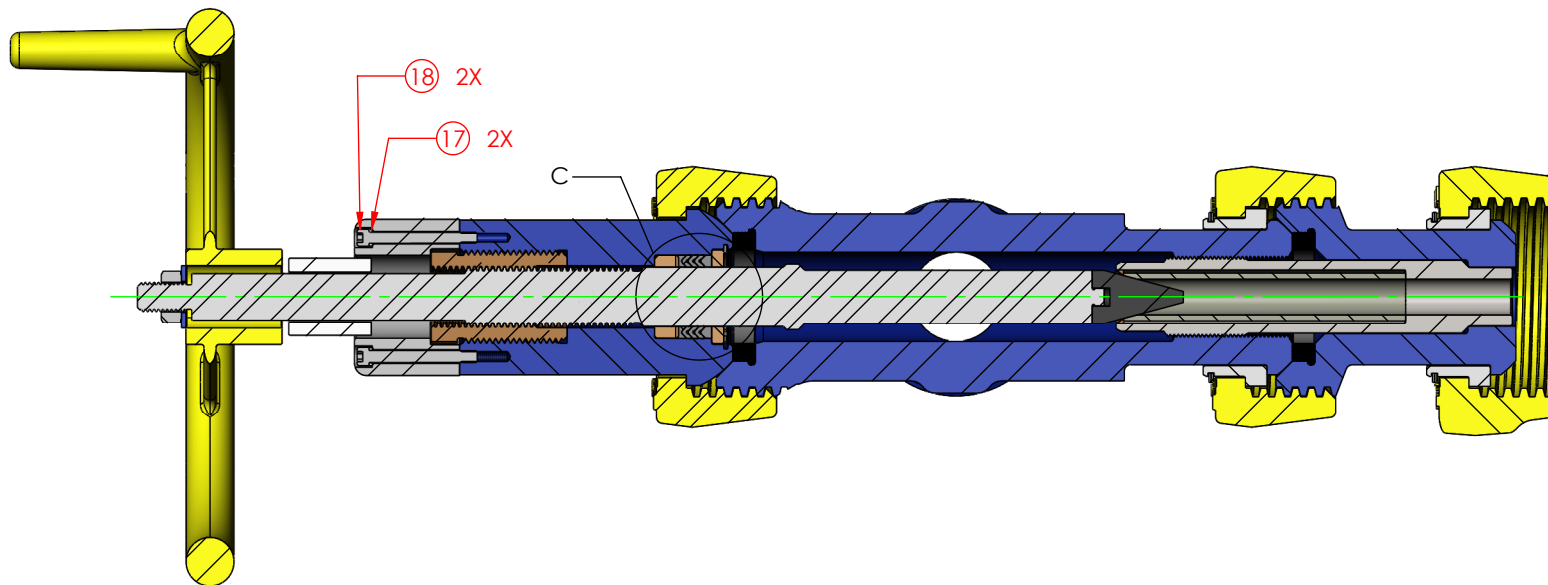

SECTION B-B

ECN NUMBER	DESCRIPTION
5372	ADJ CHOKE, 2"1502FM STD 15M 3/4"MAX

CHANGE MADE	REVISED BY	LMS	DATE	2/4/2015
1) REPLACED UC0012 WITH UC0011 2) ADDED ISOMETRIC VIEW 3) UPDATED DRAWING TEMPLATE 4) ADDED SHEET 5) ADDED DETAIL OF PACKING ORIENTAION 6) DIM WAS DECIMAL: NOW FRACTIONAL 7) 8)				

WORKING PRESSURE:	TEMPERATURE CLASS:	DRAWN BY:
15,000 PSI	PU	HAHII
RETAINED FLUIDS:	PR LEVEL:	DATE:
BB	1	3/19/02
WEIGHT:	SHEET:	PART NUMBER:
106 LBS.	SHEET 2 OF 2	CA0021

B4



300 WEST MAIN ST.
ALICE, TX 78332
www.diwmsi.com
800.242.0059
MSI IS A DIVISION OF DIXIE IRON WORKS, LTD.

THIS DRAWING IS THE PROPERTY OF DIXIE IRON WORKS, LTD. THE BORROWER AGREES BY RECEIVING THE DRAWING TO RETURN IT UPON REQUEST AND TO NEITHER REPRODUCE COPY OR FURNISH INFORMATION FROM IT TO OTHERS WITHOUT EXPRESSED WRITTEN PERMISSION OF DIXIE IRON WORKS, LTD. ALL ARTICLES MANUFACTURED IN ACCORDANCE WITH THIS DRAWING SHALL BE CONSIDERED DESIGNS OF DIXIE IRON WORKS, LTD. AND MAY NOT BE USED OR SOLD WITHOUT DIXIE IRON WORKS, LTD. WRITTEN PERMISSION.