

ITEM NO.	QTY.	PART NUMBER	DESCRIPTION
1	1	AA0049	MINI POSITION TRANSDUCER,
2	1	AA0056	HYD CYLINDER, DOUBLE-ACT 6.00" (3"STROKE)
3	1	AA0056-1	INDICATOR BRACKET PART, UPPER MOUNT 3" HYD CHOKE
4	1	AA0056-2	INDICATOR BRACKET PART, LOWER MOUNT 3" HYD CHOKE
5	1	AA0056-3	INDICATOR BRACKET PART, COVER 3" HYD CHOKE
6	1	AA0056-4	INDICATOR BRACKET PART, INDICATOR ARM 3" HYD CHOKE
7	1	CC0007	CHOKE SEAT, 2"MAX CARBIDE H-2
8	1	CC0182	CHOKE BODY, 3"1502FM STD 15M 2"MAX
9	4	CC0252	BONNET STAY BOLT, 3" 15M MSI FOR HYDRAULIC ACTUATOR
10	1	CC0287	BONNET, 3" STD 15M MSI FOR HYDRAULIC ACTUATOR
11	1	CC0314	CHOKE STEM, 2"MAX HYDRAULIC
12	1	CC0318	CHOKE PACKING 3" HYDRAULIC
13	1	CC0319	CHOKE STEM GUIDE, 3" HYDRAULIC CHOKE
14	1	CC0320	CHOKE PACKING RETAINER, 3" HYDRAULIC CHOKE
15	1	CC0321	SNAP RING, 3" HYDRAULIC BONNET
16	1	CC0322	BONNET FLANGE, 3" 15M HYDRAULIC ACTUATOR
17	1	CC0323	SEAL, HYDRAULIC CHOKE STEM 3"
18	1	CC0324	ROD SEAL RETAINER, 3" 15M HYDRAULIC ACTUATOR
19	8	HC0092	HEX NUT, 1"-8 HEAVY HEX 2H
20	8	HC0101	LOCK WASHER, 1" STANDARD
21	4	HC0124	HEX HD, 1/4"-20 x 0.50"
22	1	HC0199	GREASE FITTING, 1/4"NPT ALEMITE
23	4	HC0231	MACHINE SCREW, #10-32 x 1/2" STAINLESS w/WASHER
24	1	HC0233	EYE BOLT, #6-32 x 3/4 WITH 1/4 EYE, ZINC-PLATED w/NUT
25	2	HC0345	HEX HD, 3/8"-16 x 1.75"
26	1	HC0346	HEX NUT, 1 7/8"-12 THIN
27	3	HC0824	HEX NUT, 6-32, 5/16" WIDTH, 1/8" HEIGHT, w/NYLON INSRT
28	2	HC0825	MACHINE SCREW, #6-32 x 7/16" ROUND HEAD, SLOTTED, ZINC
29	1	OC0023	O-RING, 3" BONNET H2S (2-339)
30	1	OC0024	PAR-BACK, 3" BONNET H2S (8-339)
31	1	UC0006	NUT RETAINER SET, 3"1502
32	2	UC0009	WINGNUT, 3"1502 STD
33	1	UC0013	RESILIENT SEAL, 3"1502 STD (BUNA)
34	1	UC0015	SPIRAL RETAINER RING, 3"1502

A4

A8

CHANGE MADE		REVISED BY	LMS	DATE	10/14/2014
1) ADDED HC0824 TO BOM					
2) ADDED HC0825 TO BOM					
3) QUANTITY CHANGE FOR HCO231, HAD 6: NOW 4					
4) REMOVED BANDING TAG					
5) UPDATED HCO233 DESCRIPTION					
6) ADDED SHEET					
7) DIM WAS DECIMAL: NOW FRACTIONAL					
8) UPDATED SHEET TEMPLATE					
9) ADDED PACKING DETAIL					

ECH NUMBER		DESCRIPTION	
5264		ADJ CHOKE, 3"1502FM STD 15M 2"MAX (HYDRAULIC) IND	
WORKING PRESSURE:	TEMPERATURE CLASS:	DRAWN BY:	
15,000 PSI	PU	RSE	
RETAINED FLUIDS:	PR LEVEL:	DATE:	
BB	1	11/09/2009	
WEIGHT:	SHEET:	PART NUMBER:	REV:
381 lbs.	SHEET 1 OF 3	CA0195	A



300 WEST MAIN ST.  
ALICE, TX 78332  
www.diwmsi.com  
800.242.0059  
MSI IS A DIVISION OF DIXIE IRON WORKS, LTD.

THIS DRAWING IS THE PROPERTY OF DIXIE IRON WORKS, LTD. THE BORROWER AGREES BY RECEIVING THE DRAWING TO RETURN IT UPON REQUEST AND TO NEITHER REPRODUCE COPY OR FURNISH INFORMATION FROM IT TO OTHERS WITHOUT EXPRESSED WRITTEN PERMISSION OF DIXIE IRON WORKS, LTD. ALL ARTICLES MANUFACTURED IN ACCORDANCE WITH THIS DRAWING SHALL BE CONSIDERED DESIGNS OF DIXIE IRON WORKS, LTD. AND MAY NOT BE USED OR SOLD WITHOUT DIXIE IRON WORKS, LTD. WRITTEN PERMISSION.

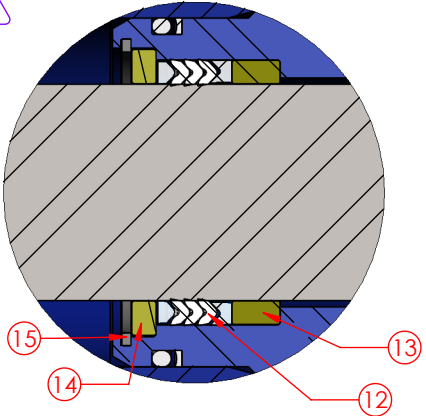
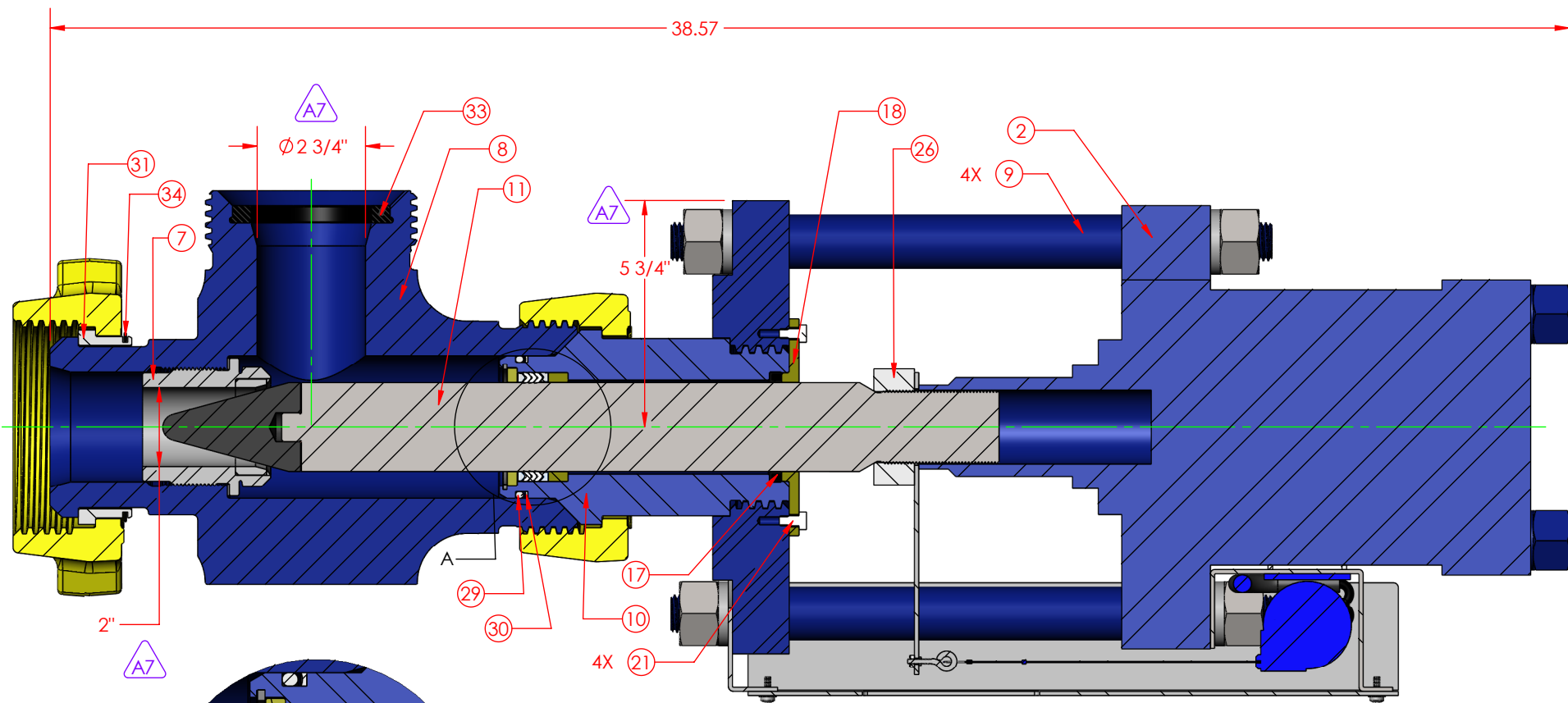

DETAIL A  
PACKING ORIENTATION

CHANGE MADE	REVISED BY	LMS	DATE	10/14/2014
-------------	------------	-----	------	------------

- 1) ADDED HC0824 TO BOM
- 2) ADDED HC0825 TO BOM
- 3) QUANTITY CHANGE FOR HCO231, HAD 6: NOW 4
- 4) REMOVED BANDING TAG
- 5) UPDATED HCO233 DESCRIPTION
- 6) ADDED SHEET
- 7) DIM WAS DECIMAL; NOW FRACTIONAL
- 8) UPDATED SHEET TEMPLATE 9) ADDED PACKING DETAIL

ECN NUMBER	5264		
DESCRIPTION	ADJ CHOKE, 3"1502FM STD 15M 2"MAX (HYDRAULIC) IND		
WORKING PRESSURE:	TEMPERATURE CLASS:	DRAWN BY:	
15,000 PSI	PU	RSE	
RETAINED FLUIDS:	PR LEVEL:	DATE:	
BB	1	11/09/2009	
WEIGHT:	SHEET:	PART NUMBER:	REV:
381 lbs.	SHEET 2 OF 3	CA0195	A

  
 300 WEST MAIN ST.  
 ALICE, TX 78332  
 www.diwmsi.com  
 800.242.0059  
MSI IS A DIVISION OF DIXIE IRON WORKS, LTD.

THIS DRAWING IS THE PROPERTY OF DIXIE IRON WORKS, LTD. THE BORROWER AGREES BY RECEIVING THE DRAWING TO RETURN IT UPON REQUEST AND TO NEITHER REPRODUCE COPY OR FURNISH INFORMATION FROM IT TO OTHERS WITHOUT EXPRESSED WRITTEN PERMISSION OF DIXIE IRON WORKS, LTD. ALL ARTICLES MANUFACTURED IN ACCORDANCE WITH THIS DRAWING SHALL BE CONSIDERED DESIGNS OF DIXIE IRON WORKS, LTD. AND MAY NOT BE USED OR SOLD WITHOUT DIXIE IRON WORKS, LTD. WRITTEN PERMISSION.

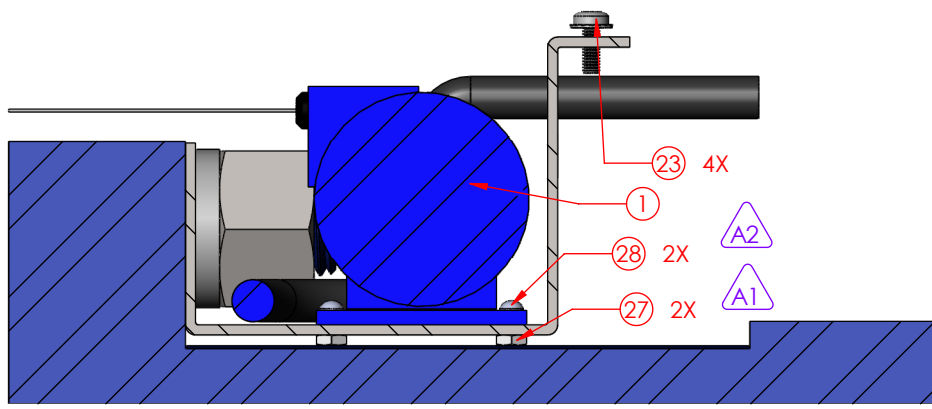
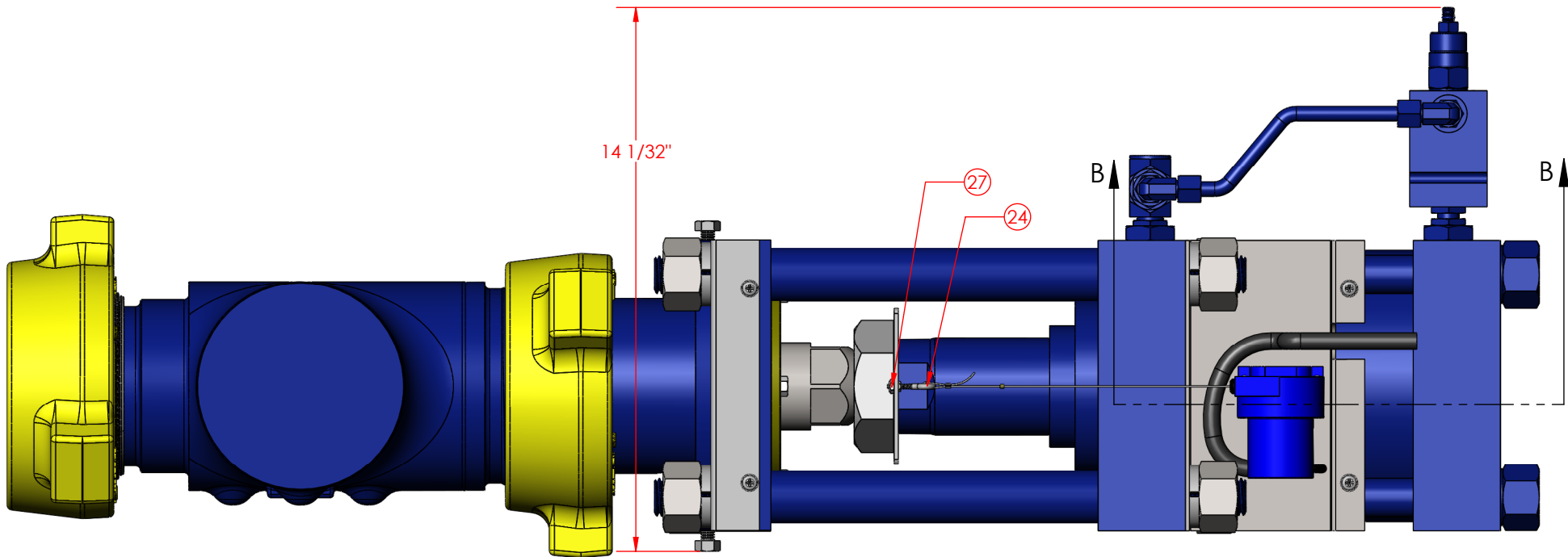

SECTION B-B

ECN NUMBER	DESCRIPTION
5264	ADJ CHOKE, 3"1502FM STD 15M 2"MAX (HYDRAULIC) IND

CHANGE MADE	REVISED BY	LMS	DATE	10/14/2014
1) ADDED HC0824 TO BOM 2) ADDED HC0825 TO BOM 3) QUANTITY CHANGE FOR HCO231, HAD 6: NOW 4 4) REMOVED BANDING TAG 5) UPDATED HCO233 DESCRIPTION 6) ADDED SHEET 7) DIM WAS DECIMAL: NOW FRACTIONAL 8) UPDATED SHEET TEMPLATE 9) ADDED PACKING DETAIL				

WORKING PRESSURE:	TEMPERATURE CLASS:	DRAWN BY:
15,000 PSI	PU	RSE
RETAINED FLUIDS:	PK LEVEL:	DATE:
BB	1	11/09/2009
WEIGHT:	SHEET:	PART NUMBER:
381 lbs.	SHEET 3 OF 3	CA0195

  
 300 WEST MAIN ST.  
 ALICE, TX 78332  
 www.diwmsi.com  
 800.242.0059  
MSI IS A DIVISION OF DIXIE IRON WORKS, LTD.

THIS DRAWING IS THE PROPERTY OF DIXIE IRON WORKS, LTD. THE BORROWER AGREES BY RECEIVING THE DRAWING TO RETURN IT UPON REQUEST AND TO NEITHER REPRODUCE COPY OR FURNISH INFORMATION FROM IT TO OTHERS WITHOUT EXPRESSED WRITTEN PERMISSION OF DIXIE IRON WORKS, LTD. ALL ARTICLES MANUFACTURED IN ACCORDANCE WITH THIS DRAWING SHALL BE CONSIDERED DESIGNS OF DIXIE IRON WORKS, LTD. AND MAY NOT BE USED OR SOLD WITHOUT DIXIE IRON WORKS, LTD. WRITTEN PERMISSION.