

ITEM NO.	QTY.	PART NUMBER	DESCRIPTION
1	2	HC0002	FLAT WASHER, 3/8" STD
2	2	HC0004	HEX HD, 3/8"-16 x 0.75"
3	1	HC0005	SOC HD, 3/8"-16 x 0.50"
4	2	HC0027	FLAT WASHER, 3/8" OVERSIZED (REGULAR)
5	1	HC0226	GREASE FITTING, 3/4" SAFETAP H2S GBH
6	1	OC0005	O-RING, 1" ADJ NUT STD (2-236 BUNA 90)
7	2	OC0006	O-RING, 1" INSERT STD (2-219 BUNA 90)
8	1	UC0002	WINGNUT, 2"1502 STD (10lbs)
9	1	UC0003	NUT RETAINER SET, 2"1502
10	1	UC0004	SPIRAL RETAINER RING, 2"1502
11	1	UC0011	RESILIENT SEAL, 2"1502 STD (BUNA)
12	2	VC0016	PLUG SEAL, 0.38" - 1.31" STD (BUNA/BRASS)
13	1	VC0036	INSERT SET, 1" STD
14	1	VC0037	PLUG, 1" STD
15	1	VC0038	ADJUSTING NUT, 1" H2S
16	1	VC0039	VLV BODY, 1" x 2"1502 STD 15M
17	1	VC0063-SC	HANDLE ADAPTER, 0.38" - 1.31" VALVE (NON-INDEXED)
18	1	VC0064	STOP COLLAR, 0.38" - 1.31" VALVE

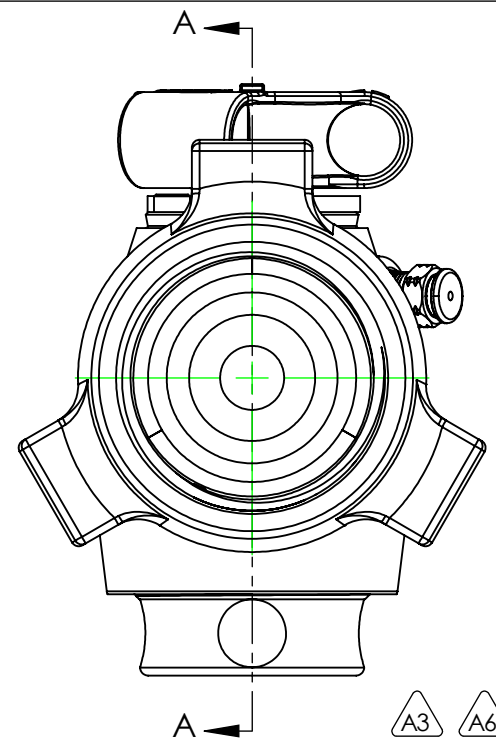
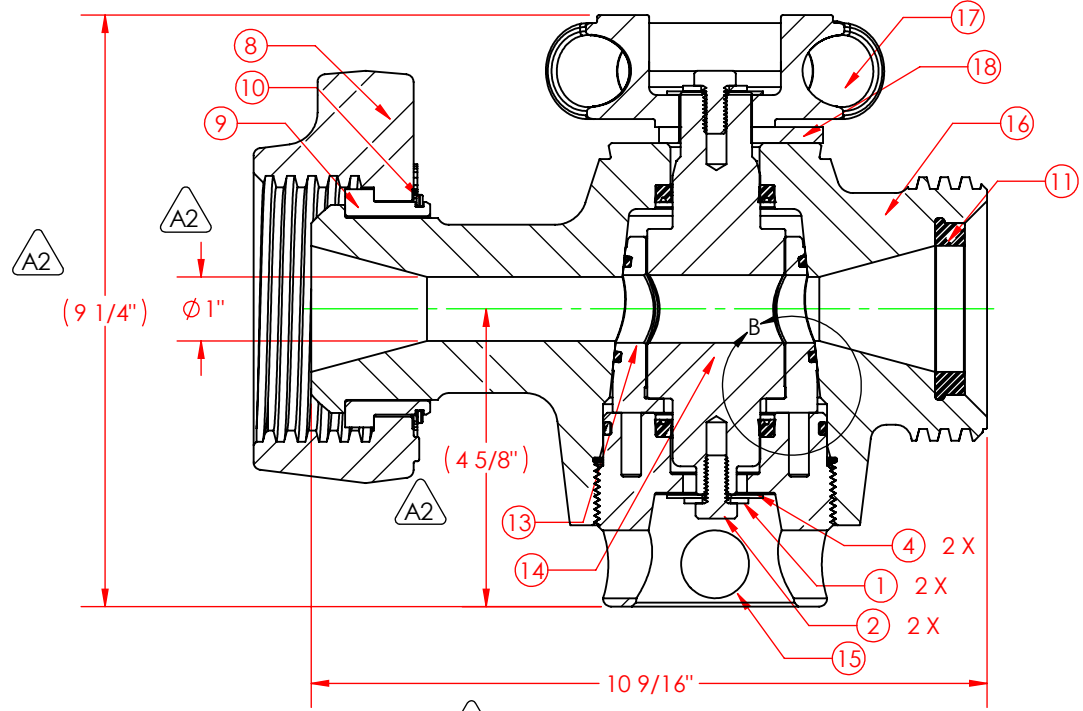

CHANGE MADE	REVISED BY	RSE	DATE	05/02/2013
1) REMOVED VC0063; REPLACED WITH VC0063-SC AND VC0064				
2) DIMS WERE DECIMAL; NOW FRACTIONAL				
3) ADDED PARENT VIEW				
4) ADDED DETAIL VIEW TO BETTER VIEW SEALS				
5) ADDED DETAIL VIEW TO BETTER VIEW STOP BOLT				
6) UPDATED DRAWING TEMPLATE				
7)				

ECN NUMBER	DESCRIPTION
4807	VALVE, 1" x 2"1502 STD 15M
WORKING PRESSURE:	TEMPERATURE CLASS:
15,000 PSI	PU
RETAINED FLUIDS:	PR LEVEL:
AA	1
DATE:	07/12/2004
WEIGHT:	SHEET:
50 lbs.	SHEET 1 OF 1
PART NUMBER:	VA0023

MSI
 300 WEST MAIN ST.
 ALICE, TX 78332
 www.diwmsi.com
 800.242.0059
 MSI IS A DIVISION OF DIXIE IRON WORKS, LTD.

THIS DRAWING IS THE PROPERTY OF DIXIE IRON WORKS, LTD. THE BORROWER AGREES BY RECEIVING THE DRAWING TO RETURN IT UPON REQUEST AND TO NEITHER REPRODUCE COPY OR FURNISH INFORMATION FROM IT TO OTHERS WITHOUT EXPRESSED WRITTEN PERMISSION OF DIXIE IRON WORKS, LTD. ALL ARTICLES MANUFACTURED IN ACCORDANCE WITH THIS DRAWING SHALL BE CONSIDERED DESIGNS OF DIXIE IRON WORKS, LTD. AND MAY NOT BE USED OR SOLD WITHOUT DIXIE IRON WORKS, LTD. WRITTEN PERMISSION.