

ITEM NO.	QTY.	PART NUMBER	DESCRIPTION
1	1	VC0110	VALVE BODY, 1.3" x 2"2202 H2S 15M
2	1	HC0226	GREASE FITTING, 3/4" SAFETAP H2S GBH
3	1	VC0013	NAME TAG- VALVE (MSI/DIXIE)
4	1	UC0017	WINGNUT, 2"2202 H2S
5	1	UC0018	NUT RETAINER SET, 2"2202 H2S
6	1	UC0019	SPIRAL RETAINER RING, 2"2202
7	1	UC0021	RESILIENT SEAL, 2"2202 H2S (HSN/SS)
8	1	VC0001	PLUG, 1.3" STAINLESS
9	1	VC0004	INSERT SET, 1.3" H2S
10	1	VC0003	ADJUSTING NUT, 1.3" VALVE
11	2	VC0112	PLUG SEAL, 1" H2S (HSN/BRASS)
12	2	OC0014	O-RING, 1.3" INSERT H2S
13	1	OC0018	O-RING, 1.3" ADJ NUT H2S
14	1	HC0006	FLAT WASHER, 1/2" STD
15	1	HC0020	SHOULDER BOLT, 1/2" x 1/2"
16	1	HC0002	FLAT WASHER, 3/8" STD
17	1	HC0004	HEX HD, 3/8"-16 x 0.75"
18	1	HC0027	FLAT WASHER, 3/8" OVERSIZED
19	1	HC0005	SOC HD, 3/8"-16 x 0.50"
20	1	VC0063	HANDLE ADAPTER, 1" PLUG VALVE

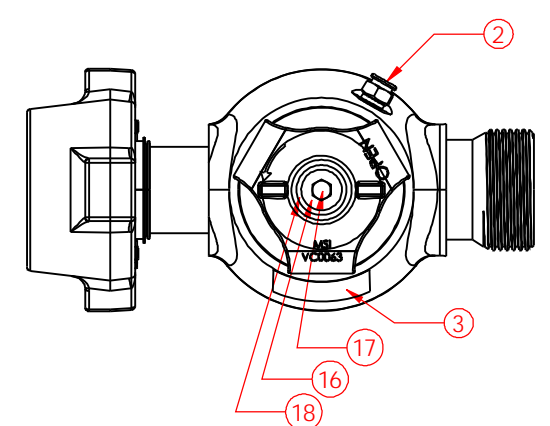

THIS DRAWING IS THE PROPERTY OF DIXIE IRON WORKS, LTD. THE BORROWER AGREES BY RECEIVING THE DRAWING TO RETURN IT UPON REQUEST AND TO NEITHER REPRODUCE COPY OR FURNISH INFORMATION FROM IT TO OTHERS WITHOUT EXPRESSED WRITTEN PERMISSION OF DIXIE IRON WORKS, LTD. ALL ARTICLES MANUFACTURED IN ACCORDANCE WITH THIS DRAWING SHALL BE CONSIDERED DESIGNS OF DIXIE IRON WORKS, LTD. AND MAY NOT BE USED OR SOLD WITHOUT DIXIE IRON WORKS, LTD. WRITTEN PERMISSION.

NOTES
 1. BREAK ALL EDGES 0.008/0.016 x 45° OR R0.008/0.016 EXCEPT THREADS.
 2. ALL MACHINED CORNERS/EDGES TO BE R0.031.
 3. ALL DIMENSIONS ARE IN INCHES (UNLESS OTHERWISE SPECIFIED).
 4. SURF START ALL HOLES/THREADS.
 5. ALL DIA/EARS TO BE CONCENTRIC WITH HOLES (UNLESS OTHERWISE SPECIFIED).
 6. MACHINED SURFACES TO BE 125µH Ra (UNLESS OTHERWISE SPECIFIED).
 7. ALL DIMENSIONS IN PARENTHESIS ARE REFERENCE DIMENSIONS (X.XXX).

THIRD ANGLE PROJECTION

UNSPECIFIED TOLERANCES	REVISION	CHANGE MADE	ECN NUMBER
FRACTIONS ±1/64 DECIMALS .XX ±0.015 XXX ±0.025 XXXX ±0.051 ANGLE ±1/2°	0		

DATUM INDICATING SYMBOL	CONCENTRICITY	ANGULARITY	RUN OUT	COUNTERBORE
POSITION	FLATNESS	PERPENDICULARITY	PARALLELISM	COUNTERSINK

DESCRIPTION	VALVE, 1.3" x 2"2202 H2S 15M
MATERIAL/HEAT TREAT/WELD PROCEDURE	SOUR SERVICE 15,000 PSI WORKING PRESSURE
WEIGHT	81.93 LBS
SHEET	SHEET 1 OF 1

COMPUTER GENERATED BY

300 West Main Street
Alice, Texas 78332

DRAWN BY	WJT
DATE	07/31/03
PART NUMBER	VA0093
REV	0