

ITEM NO.	QTY.	PART NUMBER	DESCRIPTION
1	2	HC0002	FLAT WASHER, 3/8" STD
2	2	HC0004	HEX HD, 3/8"-16 x 0.75"
3	1	HC0005	SOC HD, 3/8"-16 x 0.50"
4	2	HC0027	FLAT WASHER, 3/8" OVERSIZED
5	1	HC0226	GREASE FITTING, 3/4" SAFETAP H2S GBH
6	1	OC0005	O-RING, 1" ADJ NUT STD
7	2	OC0006	O-RING, 1" INSERT STD
8	1	UC0135	WINGNUT, 1"1502 STD
9	1	UC0136	NUT RETAINER SET, 1"1502
10	1	UC0225	RESILIENT SEAL, 1" UNION STD (BUNA)
11	1	UC0277	SPIRAL RETAINER RING, 1" 1502
12	1	VC0013	NAME TAG - VALVE(MSI/DIXIE)
13	2	VC0016	PLUG SEAL, 1" STD (BUNA/BRASS)
14	1	VC0036	INSERT SET, 1" STD
15	1	VC0037	PLUG, 1" STD
16	1	VC0038	ADJUSTING NUT, 1" H2S
17	1	VC0063	HANDLE ADAPTER, 1" PLUG VALVE
18	1	VC0307	VLV BODY, 1"x1"1502 STD 15M

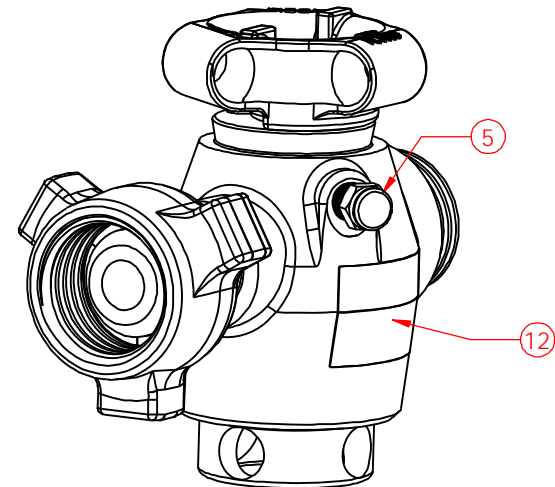
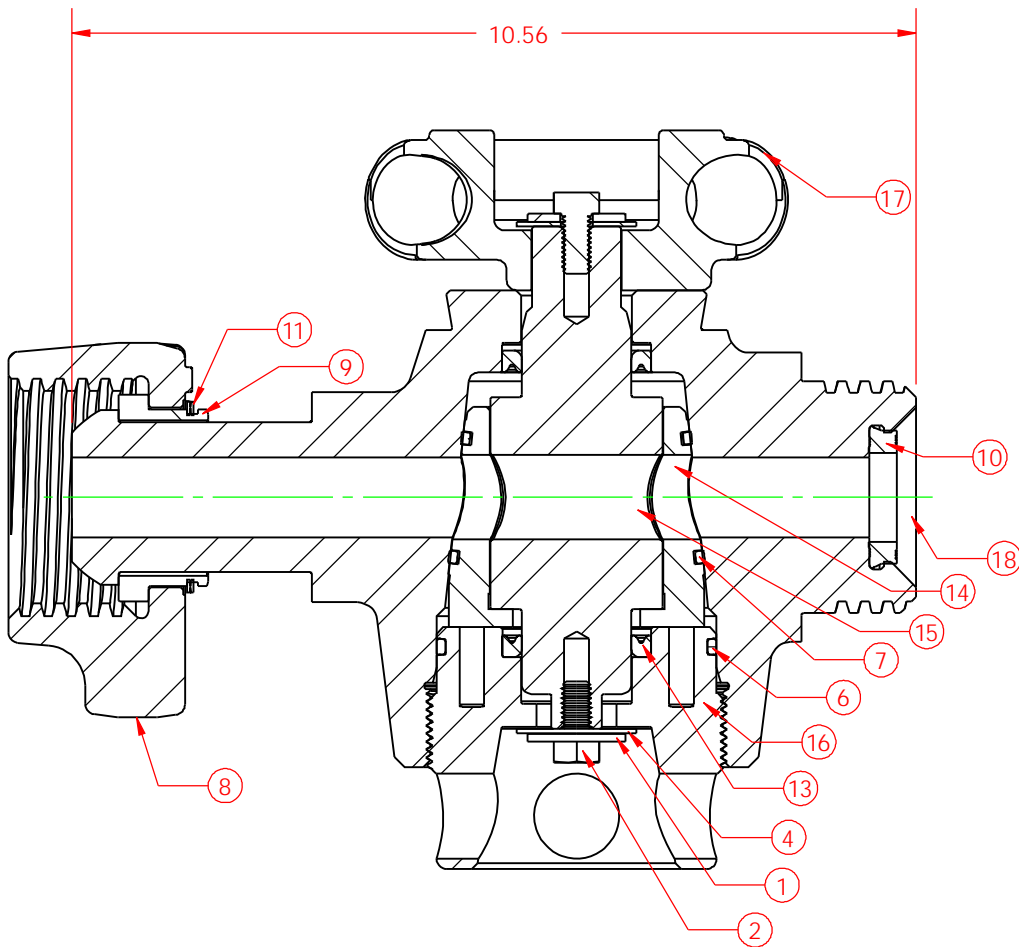

THIS DRAWING IS THE PROPERTY OF DIXIE IRON WORKS, LTD. THE BORROWER AGREES BY RECEIVING THE DRAWING TO RETURN IT UPON REQUEST AND TO NEITHER REPRODUCE COPY OR FURNISH INFORMATION FROM IT TO OTHERS WITHOUT EXPRESSED WRITTEN PERMISSION OF DIXIE IRON WORKS, LTD. ALL ARTICLES MANUFACTURED IN ACCORDANCE WITH THIS DRAWING SHALL BE CONSIDERED DESIGNS OF DIXIE IRON WORKS, LTD. AND MAY NOT BE USED OR SOLD WITHOUT DIXIE IRON WORKS, LTD. WRITTEN PERMISSION.

**NOTES**  
 1. BREAK ALL EDGES TO 0.0010 DIA ± 45° OR 90° UNLESS OTHERWISE SPECIFIED  
 2. ALL MACHINED CORNERS RADIUS TO BE R0.031  
 3. ALL DIMENSIONS ARE IN INCHES UNLESS OTHERWISE STATED  
 4. ALL DIMENSIONS OF ALL ACUTE ANGLES  
 5. ALL DIMENSIONS TO BE CONCENTRIC WITHIN 0.001  
 6. ALL DIMENSIONS OF STANDARD  
 7. ALL DIMENSIONS OF STANDARD  
 8. ALL DIMENSIONS OF STANDARD  
 9. ALL DIMENSIONS OF STANDARD  
 10. ALL DIMENSIONS OF STANDARD  
 11. ALL DIMENSIONS OF STANDARD  
 12. ALL DIMENSIONS OF STANDARD  
 13. ALL DIMENSIONS OF STANDARD  
 14. ALL DIMENSIONS OF STANDARD  
 15. ALL DIMENSIONS OF STANDARD  
 16. ALL DIMENSIONS OF STANDARD  
 17. ALL DIMENSIONS OF STANDARD  
 18. ALL DIMENSIONS OF STANDARD

**THIRD ANGLE PROJECTION**

**UNSPECIFIED TOLERANCES**

FRACTIONS ±1/64  
 DECIMALS ±0.015  
 ANGLES ±1/2°

**REVISION**  
 0

**CHANGE MADE**

**ECN NUMBER**

**DESCRIPTION**

**MATERIAL/ HEAT TREAT/ WELD PROCEDURE**

**STANDARD SERVICE**

**15,000 WORKING PRESSURE**

**WEIGHT**

**41 lbs.**

**SHEET**

**SHEET 1 OF 1**

**DATE**

**8/31/06**

**PART NUMBER**

**VA0218**

**REV**

**0**

300 West Main Street  
 Alice, TX 78332  
 www.dixieiron.com  
 800.242.0059  
 MSI is a division of Dixie Iron Works, Ltd.