

ITEM NO.	QTY.	PART NUMBER	DESCRIPTION
1	1	VC0363	VLV BODY, 2" x WS20TN H2S 15M
2	1	HC0226	GREASE FITTING, 3/4" SAFETAP H2S GBH
3	1	UC0115	SEAL, WS20 H2S 15M
4	1	UC0116	NUT RETAINER RING, WS20
5	1	UC0118	NUT MEMBER, WS20 15M
6	1	UC0119	SEAL SHROUD, WS20
7	1	VC0013	NAME TAG-VALVE (MSI/DIXIE)
8	1	VC0050	PLUG, 2"H2S
9	1	VC0049	INSERT SET, 2" H2S
10	1	VC0028	ADJUSTING NUT, 2" H2S
11	2	VC0005	PLUG SEAL, 2" H2S (BUNA/BRASS)
12	2	OC0016	O-RING, 2" INSERT H2S
13	1	OC0020	O-RING, 2" ADJ NUT H2S
14	2	HC0006	FLAT WASHER, 1/2" STD
15	2	HC0007	FLAT WASHER, 1/2" OVERSIZED
16	1	HC0008	SOC HD, 1/2"-13 x 0.50"
17	2	HC0009	HEX HD, 1/2"-20 x 1.00"
18	1	VC0061	STOP COLLAR, 2", 3", 4"
19	1	VC0062	HANDLE ADAPTER, 2", 3", 4"

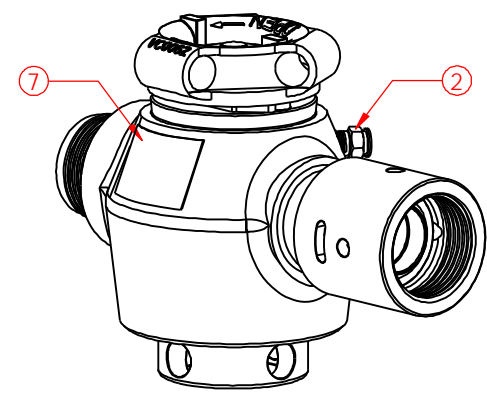

THIS DRAWING IS THE PROPERTY OF DIXIE IRON WORKS, LTD. THE BORROWER AGREES BY RECEIVING THE DRAWING TO RETURN IT UPON REQUEST AND TO NEITHER REPRODUCE COPY OR FURNISH INFORMATION FROM IT TO OTHERS WITHOUT EXPRESSED WRITTEN PERMISSION OF DIXIE IRON WORKS, LTD. ALL ARTICLES MANUFACTURED IN ACCORDANCE WITH THIS DRAWING SHALL BE CONSIDERED DESIGNS OF DIXIE IRON WORKS, LTD. AND MAY NOT BE USED OR SOLD WITHOUT DIXIE IRON WORKS, LTD. WRITTEN PERMISSION.

**NOTES**  
 1. BREAK ALL EDGES 0.008/0.016 x 45° OR R0.008/0.016 EXCEPT THREADS.  
 2. ALL FINISHED CORNERS R0.031.  
 3. ALL DIMENSIONS ARE IN INCHES (UNLESS OTHERWISE SPECIFIED).  
 4. SURF START ALL HOLES, THREADS.  
 5. ALL DIA PEEKS TO BE CONCENTRIC WITH HOLES (UNLESS OTHERWISE SPECIFIED).  
 6. FINISHED SURFACES TO BE 125µH Ra (UNLESS OTHERWISE SPECIFIED).  
 7. ALL DIMENSIONS IN PARENTHESES ARE REFERENCE DIMENSIONS (X.XXX).

THIRD ANGLE PROJECTION

UNSPECIFIED TOLERANCES	REVISION	CHANGE MADE	ECN NUMBER
FRACTIONS ±1/64 DECIMALS .XX ±0.015 .XXX ±0.005 .XXXX ±0.001 ANGLE ±1/2°	0		

	DATUM INDICATING SYMBOL		CONCENTRICITY		ANGULARITY		RUNOUT		COUNTERBORE		COUNTERSINK
	POSITION		FLATNESS		PERPENDICULARITY		PARALLELISM				

DESCRIPTION		COMPUTER GENERATED BY	
VALVE, 2" x WS20TN STD 15M (HI-TEMP)		DIXIE IRON WORKS	
MATERIAL/HEAT TREAT/WELD PROCEDURE		DRAWN BY	
STANDARD SERVICE		WJT	
15,000 PSI WORKING PRESSURE		DATE	
		07/22/03	
WEIGHT	82.57 LBS	SHEET	1 OF 1
PART NUMBER	VA0381	REV	0

