

DIXIE ENGINEERING SPECIFICATION 9-2014

MINIMUM WALL INSPECTION DATA

Rev: V 12/20/2016



GENERAL

MSI recommends regular inspection of equipment as part of normal maintenance.

Wall thickness values in this table are for cold non-shock working pressure. Vibration, high or low temperatures, large pressure pulsations and external loads can affect the integrity of the equipment and are beyond the scope of this paper. Applications where these conditions exist should warrant extra attention to equipment.

MSI recommends that trained personnel perform all inspections with properly calibrated equipment. Inspection of equipment should include a visual inspection as well as wall thickness readings. A good visual inspection can spot localized areas of wash that could possibly be missed with a “d-meter.”

Wall thickness values are for MSI equipment only. Many of the connections listed are standard in the oil patch and made by different manufacturers. However, the values listed are based on MSI material specifications and should not be applied to any other equipment other than that manufactured by MSI.

For flange neck wall thickness please contact MSI Engineering.

SPECIFIC – (following pages)

Equipment Minimum Wall Thickness by Working Pressure

The following comments apply to all subsequent minimum wall tables:

** Tapered bore; thickness will vary with location. Thickness specified is typical of most products.

*** Stepped OD; thickness will vary with location.

**** WingSeal® connections have a seal shroud that protects the WingSeal® area and aids in assembly. Wash in the seal shroud area may dislodge the shroud from its proper location.

Notes:

1. All End Connections may experience erosion in severe applications. If equipment is at or near minimum wall it should not be put into applications where severe erosion is expected.
2. Corrosion, Pitting, and Dings on the sealing surfaces of all connections can compromise the sealing ability of the end connection. Always protect and lubricate sealing surfaces after use.

6000 PSI Working Pressure

End Connection Description	New Wall Thickness	Minimum Wall	
		STD	H2S
3"602 MALE (NON-REMOVABLE)	0.750	0.525	
4"602 MALE (NON-REMOVABLE)	0.780	0.546	
3"602 FEMALE	0.670	0.469	
4"602 FEMALE	0.765	0.536	
3"1502/602/1002 MALE (REMOVABLE)	0.670	0.469	
4"602/1002 MALE (REMOVABLE)**	0.625	0.438	

10,000 PSI Working Pressure

End Connection Description	New Wall Thickness	Minimum Wall,	
		STD	H2S
1.5"1002 MALE (NON-REMOVABLE)***	0.498	0.348	
3"1002 MALE (NON-REMOVABLE)	0.745	0.522	
4"1002 MALE (NON-REMOVABLE)**	0.750	0.525	
6"1002 MALE (NON-REMOVABLE)	1.435	1.005	
1"1502 FEMALE	0.750	0.525	
1.5"1002 FEMALE	0.750	0.525	
1.5"1502 FEMALE	0.830	0.581	
2"1502 FEMALE	0.845	0.592	
3"1002 FEMALE	1.015	0.711	
3"1502 FEMALE	0.970	0.679	
4"1002 FEMALE**	0.620	0.525	
4"1502 FEMALE	0.720	0.550	
6"1002 FEMALE	1.315	0.921	
1"1502 MALE (REMOVABLE)	0.438	0.306	
1.5"1502 MALE (REMOVABLE)	0.627	0.439	
2"1502 MALE (REMOVABLE)	0.545	0.382	
3"1502/602/1002 MALE (REMOVABLE)	0.670	0.469	
4"602/1002 MALE (REMOVABLE)	0.625	0.500	
4"1502 MALE (REMOVABLE)	0.813	0.569	
1"1502 NPST Flowline (1.315 OD)	0.25	0.136	
1.5"1002 NPST Flowline STD ONLY (1.935 OD)	0.27	0.138	NA
1.5"1502 NPST Flowline (1.935 OD)	0.27	0.196	
2"1502 NPST Flowline (2.375 OD)	0.345	0.245	
3"1502 NPST Flowline (3.500 OD)	0.54	0.363	
4" 1002 NPST Flowline STD ONLY (4.500 OD)	0.46	0.330	NA
4" 1502 NPST Flowline (4.500 OD)	0.625	0.470	

15,000 PSI Working Pressure

End Connection Description	New Wall Thickness	Minimum Wall,	
		STD	H2S
4.375"ACME BOX	1.375	0.963	
4.375"ACME PIN STD ONLY	0.594	0.450	NA
6.38"ACME PIN	1.000	0.65	0.95
8.00"ACME PIN STD ONLY	1.244	1.00	NA
1"1502 MALE (NON-REMOVABLE)	0.593	0.415	
1.5"1502 MALE (NON-REMOVABLE)	0.825	0.578	
2"1502 MALE (NON-REMOVABLE)	0.765	0.536	
3"1502 MALE (NON-REMOVABLE)	0.875	0.725	
1"1502 FEMALE	0.75	0.525	
1.5"1502 FEMALE	0.83	0.581	
2"1502 FEMALE	0.845	0.592	
2"2202 FEMALE	0.8125	0.569	
3"1502 FEMALE STD ONLY	0.97	0.679	NA
3"2202 FEMALE	1.22	0.900	
4"1502 FEMALE STD ONLY	0.72	0.625	NA
1"1502 MALE (REMOVABLE)	0.4375	0.306	
1.5"1502 MALE (REMOVABLE)	0.627	0.439	
2"1502 MALE (REMOVABLE) STD ONLY	0.545	0.382	NA
2"2202 MALE (REMOVABLE)	0.607	0.425	
3"1502 MALE (REMOVABLE) STD ONLY	0.67	0.469	NA
3"2202 MALE (REMOVABLE)	1.1575	0.900	
4"1502 MALE (REMOVABLE) STD ONLY	0.8125	0.625	NA
WS20 THREAD****	0.607	0.406	0.478
WS20 NUT****	0.530	0.397	0.465
WS25 THREAD****	0.779	0.503	0.596
WS25 NUT****	0.703	0.535	0.622
WS30 THREAD****	0.904	0.604	0.713
WS30 NUT****	0.770	0.625	0.724
WS20 Flowline Body	0.700	0.376	0.457
WS30 Flowline Body	1.022	0.563	0.686
1"1502 NPST Flowline STD ONLY (1.315 OD)	0.25	0.146	NA
1.5"1502 NPST Flowline STD ONLY (1.935 OD)	0.27	0.211	NA
2"1502 NPST Flowline STD ONLY (2.375 OD)	0.345	0.263	NA
3"1502 NPST Flowline STD ONLY (3.500 OD)	0.54	0.390	NA
4" 1502 NPST Flowline STD ONLY (4.500 OD)	0.625	0.505	NA
Integral Flowline – See page 9			

20,000 PSI Working Pressure

End Connection Description	New Wall Thickness	Minimum Wall, STD
2"2002 FEMALE	0.962	0.75
2"2002 MALE (REMOVABLE)	0.607	0.50
WS20 THREAD****	0.607	0.501
WS20 NUT****	0.530	0.487

Male End Connections

1. Check Thickness along length of end connection
2. Check Maximum Bore
3. Check seal areas for corrosion that will compromise sealing

Size	*Max Bore
1"	1.12
1.5" 1002	1.79
1.5" 1502	1.50
2" 1502	2.17
2" 2002 / 2202	1.40
3"	3.25
4"	4.25

* Maximum Bore size should be checked as this shoulder retains the resilient seal. Bore sizes above the listed amount may compromise the sealing ability of the resilient seal.

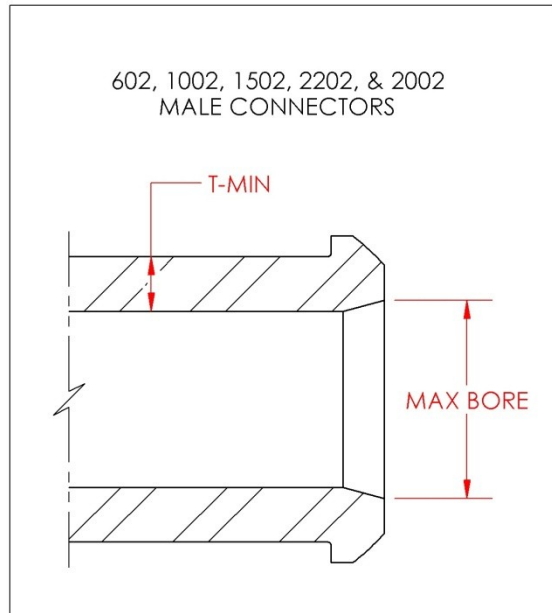

Female End Connections

1. Check Thickness along length of end connection
2. Check Maximum Bore
3. Check seal areas for corrosion that will compromise sealing

Size	*Max Bore
1"	1.12
1.5" 1002	1.79
1.5" 1502	1.50
2" 1502	2.17
2" 2002 / 2202	1.40
3"	3.25
4"	4.25

* Maximum Bore size should be checked as this shoulder retains the resilient seal. Bore sizes above the listed amount may compromise the sealing ability of the resilient seal.

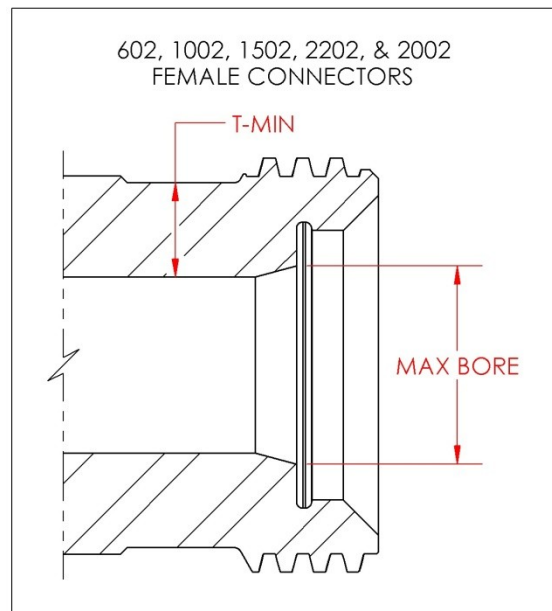

WS Nut End Connections

1. Check Thickness along length of end connection
2. Check Maximum Bore
3. Check seal areas for corrosion that will compromise sealing

Size	*Max Bore
WS20	2.04
WS25	2.64
WS31	3.13

* Maximum Bore size should be checked as this shoulder retains the seal shroud in place, which protects the WingSeal® and aids in assembly. Bore sizes above the listed amount may compromise the integrity of the WingSeal® during assembly and operation.

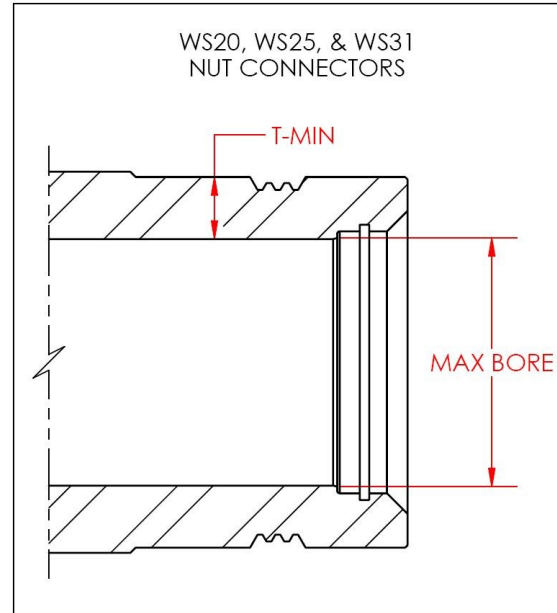

WS Thread End Connections

1. Check Thickness along length of end connection
2. Check Maximum Bore
3. Check seal areas for corrosion that will compromise sealing

Size	*Max Bore
WS20	2.04
WS25	2.64
WS31	3.13

* Maximum Bore size should be checked as this shoulder retains the seal shroud in place, which protects the WingSeal® and aids in assembly. Bore sizes above the listed amount may compromise the integrity of the WingSeal® during assembly and operation.

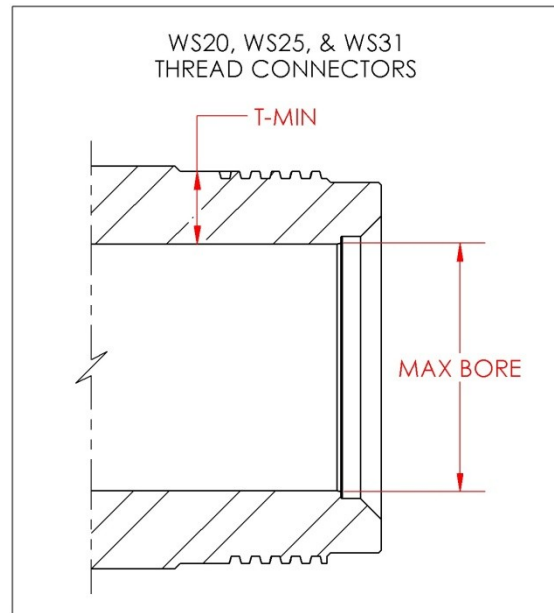

Inspection of Tees, Chokes, Crosses, and Ells

*Size: 1" 2" 3" 4" Std/H2S

1. Check all end connections
2. Check target areas and side walls

Targets	Side "A"
0.75	0.70

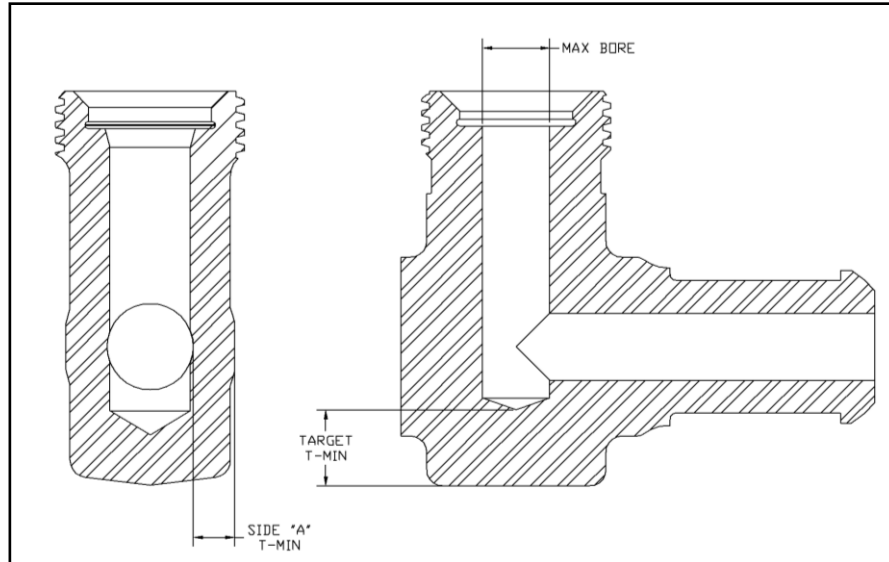

Inspection of Valves

1. Check all end connections
2. Check internal seal areas for wash or corrosion that will compromise sealing

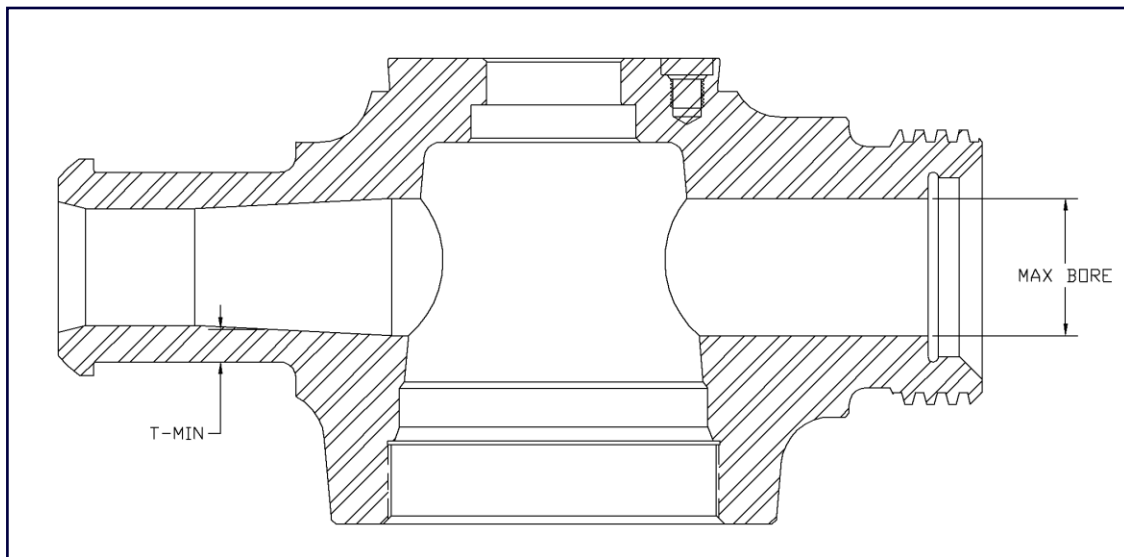

Inspection of NPST Flowline

1. Check all end connections for damage or corrosion
2. Check sealing surfaces for corrosion
3. Check tubing wall thickness
4. Check for wash under Subs

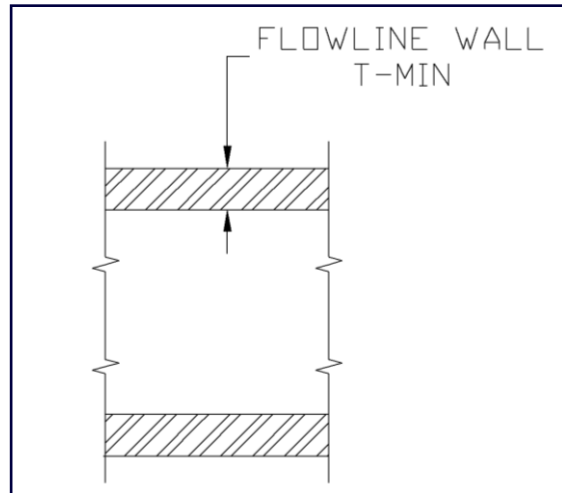

Inspection of Integral Flowline

1. Check all end connections for damage or corrosion
2. Check sealing surfaces for corrosion
3. Check tubing wall thickness
4. Check for wash at ends

2"1502 Integral Flowline STD ONLY	New Wall		Min Wall	
	Neck	Tube	Neck	Tube
	0.63	0.44	0.340	0.300

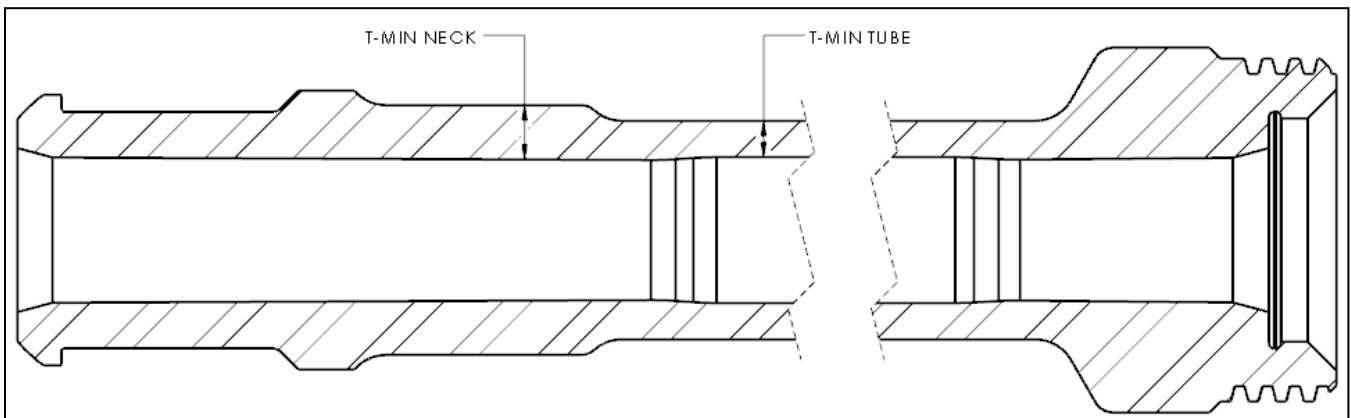

Inspection Relief Valve Body

1. Check minimum wall at specified knob location.
2. Check sealing surfaces for corrosion/erosion.
3. Check bores at internal openings
4. Check end connections accordingly

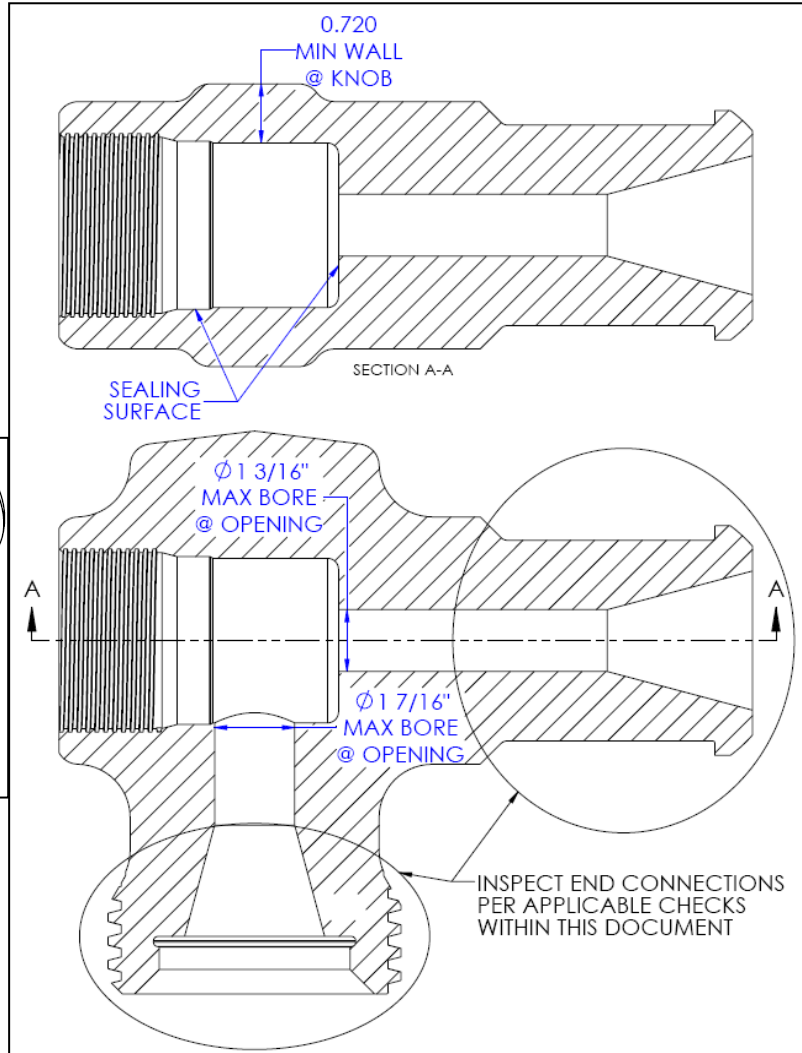
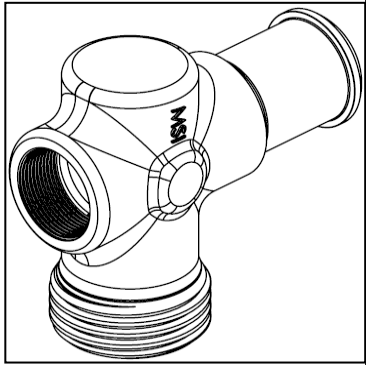

Inspection of ACME Box & Pin Connections

1. Check all threads for damage
2. Check sealing surfaces for corrosion
3. Check wall thickness

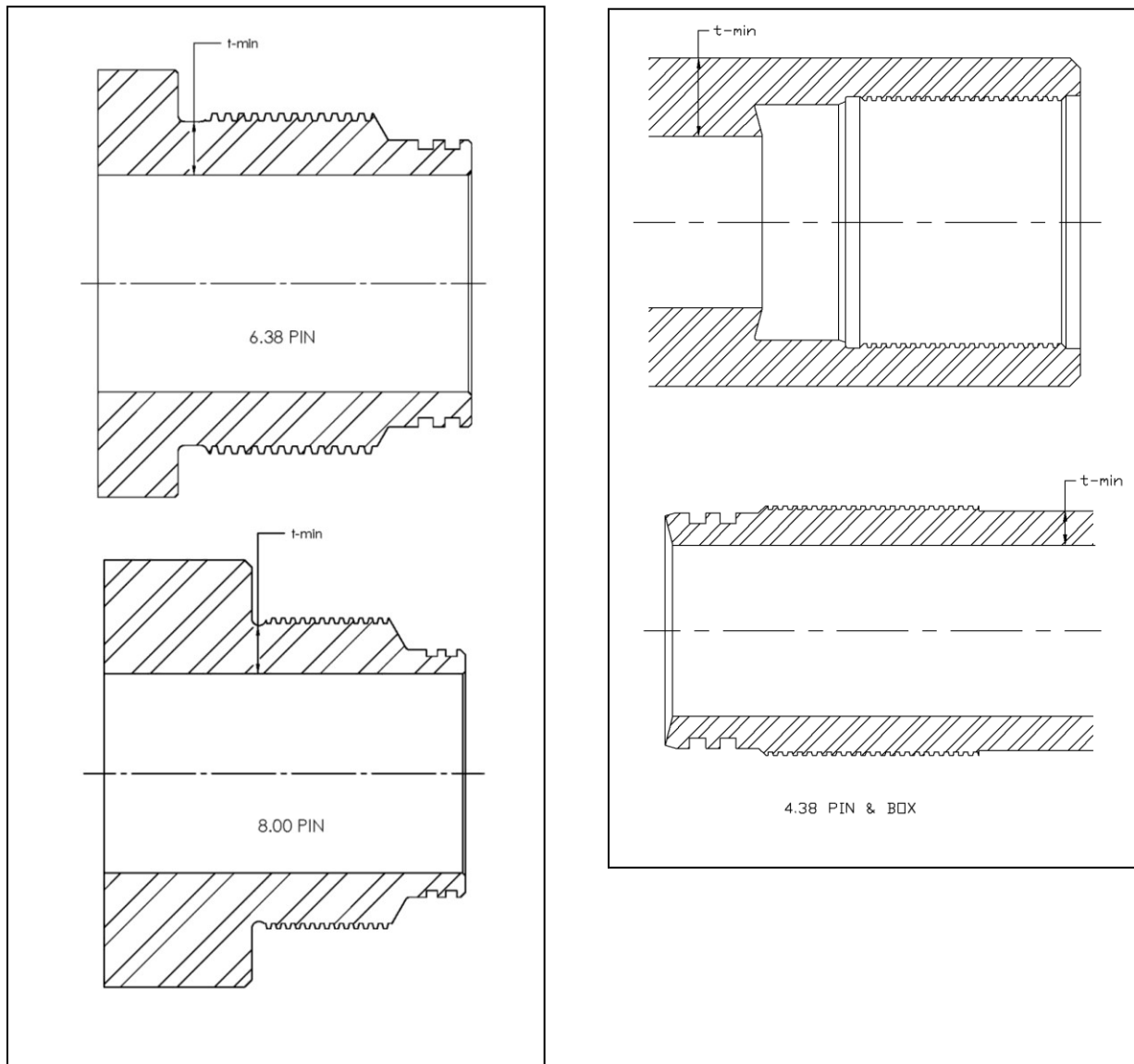

* The box end for the 6.38 and 8.00 ACME connections is not the limiting factor for end connection wall thickness due to the sealing method and valve configuration. However, the box end shall be properly inspected for corrosion, pitting, or galling to ensure proper sealing function.

Changes Made:	
1.	Added 2" integral flowline.